

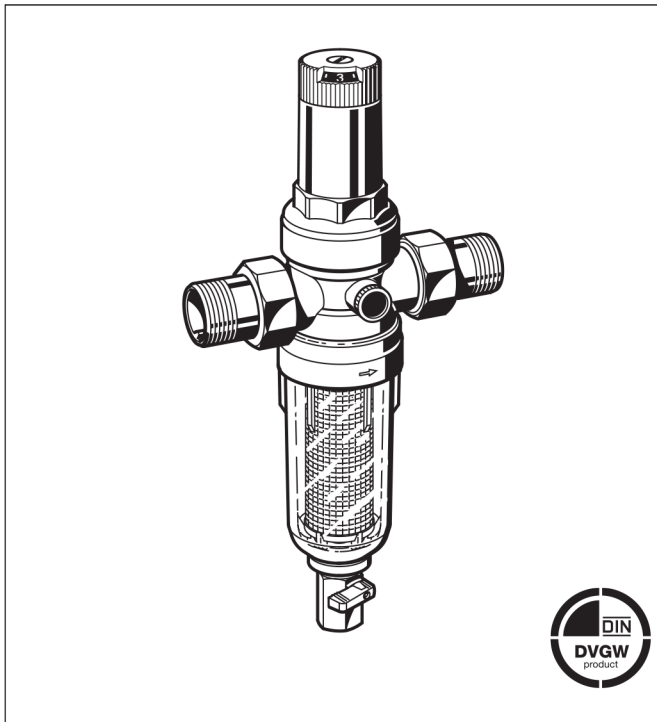

MiniPlus FK06

Filter combination

Product specification sheet



Construction

The filter combination comprises:

- Housing with pressure gauge connections on both sides
- Threaded connections
- Valve insert complete with diaphragm and valve seat
- Spring bonnet with setting knob and scale
- Adjustment spring
- Fine filter in clear filter bowl
- Ball valve
- Double wing wrench
- Pressure gauge not included (see accessories)

Materials

- Dezincification resistant brass housing
- Brass threaded connections
- High-quality synthetic material valve insert
- High-quality synthetic material spring bonnet with adjustment knob and setting scale
- Spring steel adjustment spring
- Stainless steel fine filter
- Shock-resistant, clear transparent synthetic material filter bowl
- Fibre-reinforced NBR diaphragm
- NBR seals

Application

MiniPlus FK06 rinsable filter combinations ensure a continuous supply of filtered water. They prevent the ingress of foreign bodies such as particles of rust, strands of hemp and grains of sand. The accumulation of foreign particles in the base of the filter bowl can be easily removed by rinsing the filter. The pressure reducing valve prevents over-pressure damage and reduces the water consumption. The appliances correspond to DIN/DVGW requirements.

Compact in size, the device can be fitted even where space is limited.

Special Features

- DIN/DVGW approved
- The set pressure is directly indicated on the set point scale
- The adjustment spring is not in contact with the potable water
- The valve insert is of high quality synthetic material and can be fully exchanged
- Filtered water supply even during rinsing
- Inlet pressure balancing - fluctuating inlet pressure does not influence outlet pressure
- Shock resistant clear synthetic material filter bowl enables easy checking of filter contamination
- Filter and complete filter bowl are replaceable
- Meets KTW recommendations for potable water

Range of Application

Medium	Water
Inlet pressure	Maximum 16.0 bar
Outlet pressure	1.5 - 6.0 bar

The filter is constructed for drinking water installations. In case of a process water application the filter has to be proven individually.

Technical Data

Installation position	Horizontal with filter bowl downwards
Operating pressure	Maximum 16.0 bar
Operating temperature	Maximum 40 °C
Connection size	1/2", 3/4", 1", 1 1/4"

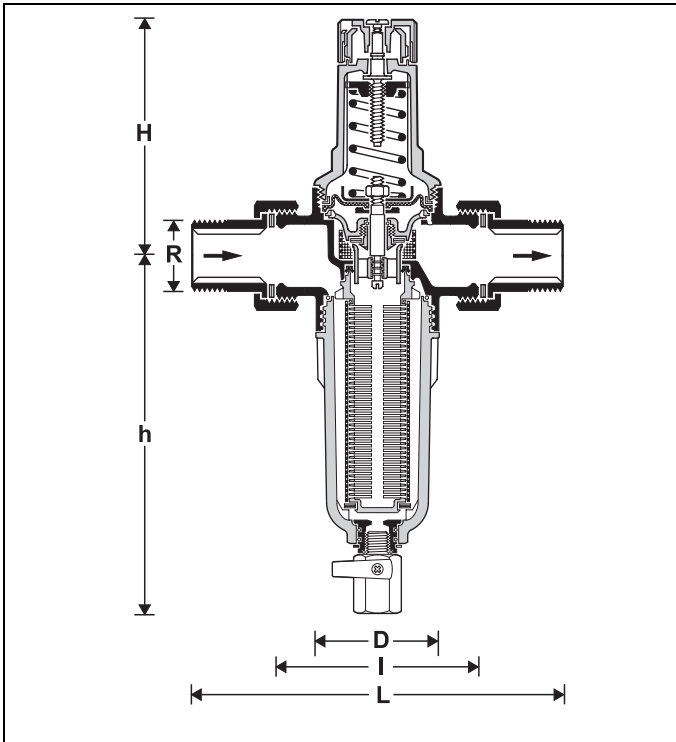

Method of Operation

The filter combination integrates a pressure reducing valve and a rinsable fine filter cartridge in one appliance.

During normal operation, water flows through the filter mesh to the body outlet. To rinse the filter, the ball valve is opened which discharges the dirt particles. A continuous supply of filtered water is available also during the rinse cycle.

The integral pressure reducing valve functions on a balanced force principle whereby the force exerted by a diaphragm is balanced against the force of an adjustment spring. The inlet pressure has no influence on opening or closing of the valve. Inlet pressure fluctuation does not therefore affect the outlet pressure.

Options

FK06-...AA = Threaded union connectors,

┌ filter mesh size 100 µm

└ Connection size

Connection size	R	1/2"	3/4"	1"	1 1/4"
Nominal size diameter	DN	15	20	25	32
Weight	approx. kg	0.7	1.0	1.5	1.7
Dimensions	mm				
	L	140	160	180	197
	I	80	90	100	105
	H	89	89	111	111
	h	156	156	180	180
	D	54	54	61	61
k _{vs} -value		2.5	2.9	6.0	6.2
DIN/DVGW Approval No.		NW-9311 BO 0223		-	

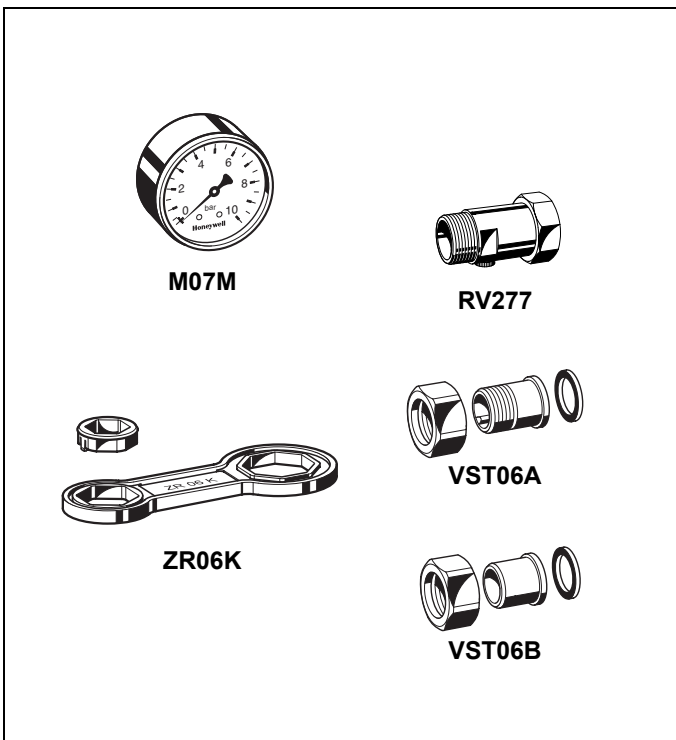

Accessories

M07M Pressure gauge

Housing diameter 63 mm, rear connection thread G¹/₄". Ranges: 0 - 4, 0 - 10, 0 - 16 or 0 - 25 bar. Please indicate upper value of pressure range when ordering

ZR06K Double-ring wrench

For removing spring bonnet

RV277 Inlet check valve

Available in sizes R¹/₂" - 2"

VST06 Connection set

Connection set

A = Threaded male connection;

B = Solder union connection

Installation Example

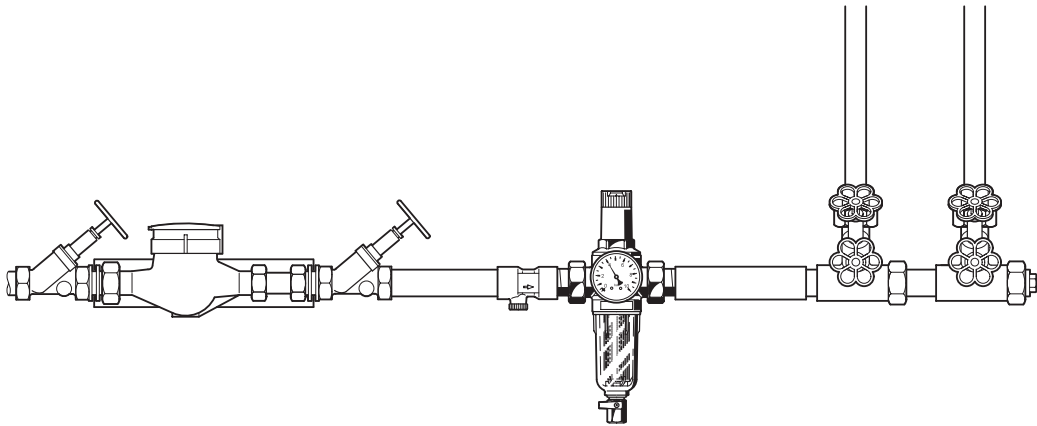

Installation Guidelines

- Install in horizontal pipework with filter bowl downwards
 - This position ensures optimum filter efficiency
- Install shutoff valves
- Ensure good access
 - Degree of contamination can be easily seen with clear filter bowl
 - Simplifies maintenance and inspection
- The installation location should be protected against frost
- Fit immediately after water meter
 - Corresponds to DIN 1988, Part 2

Typical Applications

Filter combinations of this type are suitable for all types of household installations. They can also be used for commercial and industrial applications within the limits of their specifications.

Filter combinations of this type are installed:

- Where space is limited
- Where there is existing metal or plastics pipework
- If the static pressure exceeds the maximum permissible operating pressure of an installation
- As protection against noise if the static pressure at take off points exceeds 5.0 bar (DIN 4109: Noise protection in high buildings)
- If pressure fluctuations in the downstream system must be avoided
- If the downstream system includes appliances which must be protected against dirt

Flow Diagram

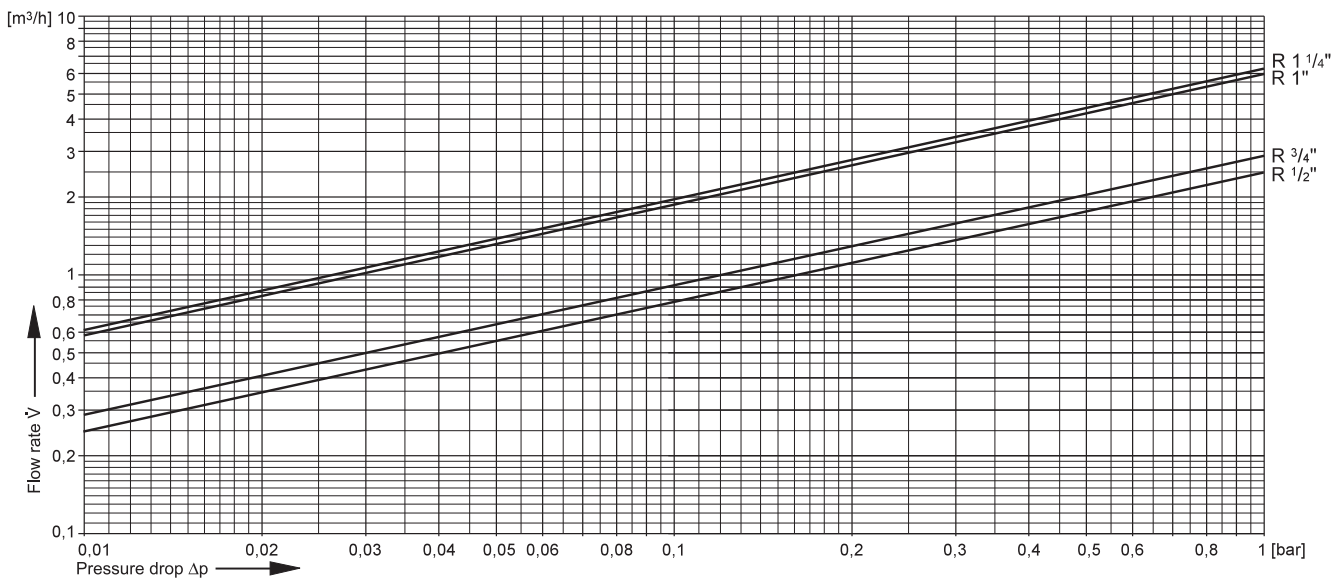

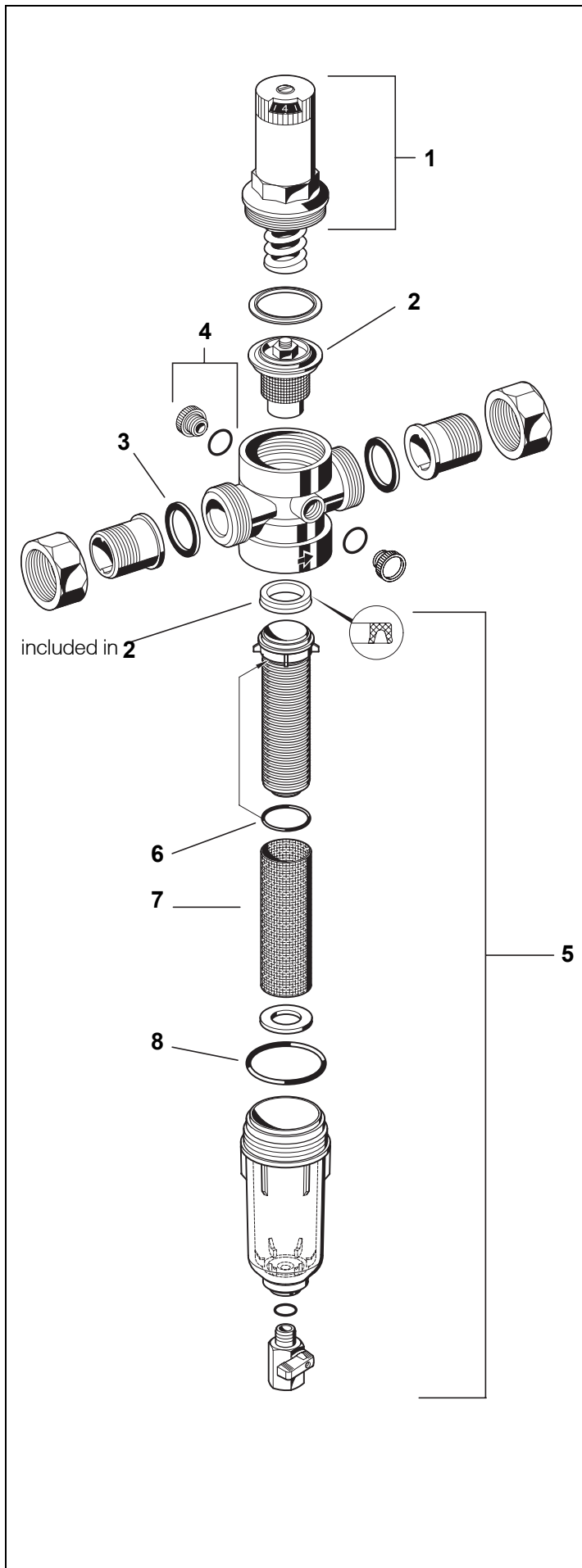

Spare Parts

MiniPlus FK06 Filter Combinations (From 2000 onwards)

No.	Description	Dimension	Part No.
1	Spring bonnet	1/2" + 3/4"	0901515
	complete	1" + 1 1/4"	0901516
2	Valve cartridge complete	1/2" + 3/4"	D06FA-1/2
	(without filter insert)	1" + 1 1/4"	D06FA-1B
3	Seal ring set (pack of 10)	1/2"	0901443
		3/4"	0901444
		1"	0901445
		1 1/4"	0901446
4	Blanking plug with O-ring R1/4" (pack of 5)		S06K-1/4
5	Clear filter bowl complete with filter and carrier body	1/2" + 3/4"	KF06-1/2A
		1" + 1 1/4"	KF06-1A
6	O-ring-set for carrier body (pack of 10)	1/2" + 3/4"	0903127
		1" + 1 1/4"	0903128
7	Replacement filter insert	1/2" + 3/4"	AS06-1/2A
		1" + 1 1/4"	AS06-1A
8	O-ring-set for filter bowl (pack of 10)	1/2" + 3/4"	0901246
		1" + 1 1/4"	0901499
9	Double ring wrench For removing filter bowl (no fig.)	1/2" - 1 1/4"	ZR06F



hydrotechnology
WATER TREATMENT

hydrotechnology di Matteo Giacopini
Via Ho Chi Minh, 6 - 42020 S. Polo d'Enza (RE) - Italy
Phone +39 320 3091135

hydrotechnology.giacopini@gmail.com
www.ht-hydrotechnology.com

P. IVA 02562140356